



Water Pumps at Keokuk Municipal Water Works



## Customer Success Story

# Keokuk Municipal Water Works Keokuk, IA



Keokuk Water Treatment Facility Main Menu

*"The system has been in for many years, and it has been very reliable. The migration from the older version GraphWorX to the new has been a success. All aspects of the change-over from interfacing and gathering data from the Rotork Valve Package (Modbus) to the new OPC interface from ICONICS for the Allen Bradley PLC5 were completed in a timely manner with no downtime."*

**Bill Cole**  
General Manager  
Keokuk Municipal Water Works

### About Keokuk Municipal Water Works

Serving over 4,800 customers, Keokuk Municipal Water Works is responsible for providing its residential, commercial and industrial customers with a high-quality and reliable water supply. The Water Works service area, 105 miles of pipe within a 20-square-mile area, includes the entire incorporated area of the city of Keokuk, Iowa. Additionally, the water system serves two small private water systems outside the Keokuk corporate limits.

### ICONICS Software Deployed

Keokuk Water has installed ICONICS GENESIS32™ after evaluating ICONICS, Wonderware and Intellution HMI software products. The GENESIS32 modules used are TrendWorX™32 and AlarmWorX™32. These ICONICS products were selected because of their cost

effectiveness, ActiveX®-based technologies, ability to log data to Microsoft SQL Server, and local support. GENESIS32 replaces a stand-alone, proprietary system.

### Project Summary

The GENESIS32 system monitors all functions of the plant, from analytical equipment to Rotork Valve: control, monitor, alarm, trend, etc. The GENESIS32 system connects to an Allen-Bradley Series 5 and MicroLogix PLCs, ProLinx Hart Multiplexer, Rotork Valve System, Hach Analytical Equipment, Toshiba Drive Systems, and Rosemount Field Devices. The system has one Allen Bradley OPC Server, one alarm and trend server, and five Browser nodes. The system has 1,500 digital and 225 analog tags. The ICONICS GENESIS32 system connects via Modbus to the Rotork Valve Package. The system provides better methods of data monitoring and alarm logging. It also provides much better

visual representation of the water treatment process, with the browser nodes located strategically throughout the facility. The ICONICS 16-bit to 32-bit graphics translator made for a fast and easy upgrade from GENESIS™ for Windows version 3.5x to GENESIS32 version 6.x.

## Project Overview

Several large centrifugal pumps move Mississippi river water (raw water) to the plant and into the head tank from the river. Prior to the head tank several chemicals, including oxidized soluble manganese, a liquid alum, a coagulate aid, cationic polymer, and carbon, are fed directly into the raw water.

pass through into the filters. The clarified water off the top of the claricones goes to the re-carbonation tank, and has a high pH and concentration of calcium carbonate. Carbon dioxide gas is added to the tank to form soluble calcium bicarbonate and to reduce the pH to a level at which the water is stabilized to prevent scale formation or corrosion of water pipes. The water is then gravity-fed into the filters. There are four sand filters used to remove what little particulate was not removed in the claricones. Chlorine is then added.

After the water goes through the filters it enters the storage well. Here liquid ammonia is added to combine with the free available chlorine, forming a weaker form of

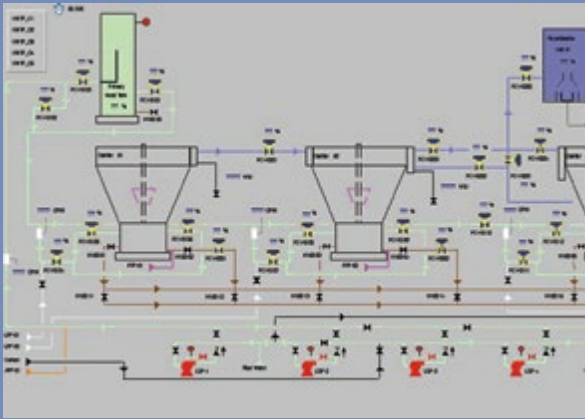

*Monitoring/Control Screen at Keokuk Municipal Water Works*

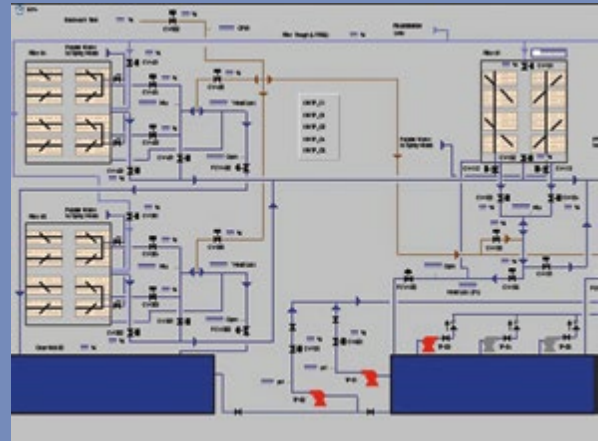

*Another Monitoring/Control Screen*

After the raw water is mixed with the chemicals, it goes to four claricone Clarifier units where an anionic polymer can be fed directly into the top sludge blanket in the Clarifiers. Lime is also introduced at the bottom in a slurry form to remove the minerals that cause calcium hardness. The entrance velocity of the raw water promotes mixing within the vessel's lower cylinder. The slower rotation in the middle section provides good particle contact and flocculation. There is little turbulence in the top section of the claricone, which makes for good settling of the particles and produces clarified water.

The water passes upward through the sludge blanket, which traps slowly settling particles that would otherwise

disinfectant. The treated water is then pumped into the distribution system and to two elevated storage towers through one of four high service pumps. All the plant control is achieved through the use of ICONICS GENESIS32 software.

## Conclusion

ICONICS has worked closely with Keokuk Water to make this project a success. Keokuk Water participates in the ICONICS SupportWorX™ maintenance program for upgrades and access to technical support.